

# International Andalusian and Lusitano Horse Association

## WORKING EQUITATION RULES FOR 2011 National Show

*These rules are a condensation of a larger set of rules being developed. While the full set of rules has five levels of competition (novice, basic, preliminary, intermediate, and advanced), these rules only address the Basic and Intermediate levels. The team cattle phase is also not included in this version of the rules. Some obstacles have not been included in these rules and in their place the word "Reserved" has been noted.*

### **WE 101 Objective and General Principles**

- 1 The Working Equitation discipline was created with the objective of enhancing the equestrian techniques developed in countries whose riders use horses in different aspects of field work. The event, therefore, provides an opportunity for the simultaneous comparison and exhibition of sporting skill and display of cultural heritage.
- 2 The objective of Working Equitation is to exhibit the horse in a variety of environments that showcase his ability to be a creature of utility in partnership and harmony with the rider. The horse is shown as he would be seen in a working environment on the ranch or farm. The rider is dressed as he would be if he were in the fields with his mount. The emphasis is on the utility of the horse and the skill of the rider, not on their outward appearance.
- 3 Definitions:
  - a. Phase- one part of the Working Equitation competition. Each phase is scheduled as a separate class, with performance in each phase contributing to the overall placing in the Working Equitation competition. Phases are described in more detail in sub-paragraph 5, below.
  - b. Basic Level: Trot is allowed in lieu of canter between obstacles. Basic dressage test and obstacles are used.
  - c. Intermediate Level: Canter is required between obstacles. Intermediate dressage test and obstacles are used.
  - d. Amateur – Rider is classified as an amateur according to USEF rules. Amateurs may compete in amateur or open classes.
  - e. Professional – Rider is classified as a professional according to USEF rules. Professionals may compete in open classes only.
- 4 Use of riders' hands
  - a. Basic level riders may use one or two hands on the reins and will not be penalized if switching from one hand to two, or vice versa, either between phases or during a phase.
  - b. Intermediate level riders may elect to use one or two hands on the reins, but must be consistent in their choice across and within all phases. Switching between one and two hands will be cause for elimination, except when the instructions for completing the obstacle require the use of one hand free of the reins.
  - c. Competitors in the Intermediate level, when they have elected to use one hand, will be eliminated if their free hand brushes or strokes the horse's neck in front of their rein or if their free hand provides any form of assistance in guiding the mount. Any adjustment to the reins using the free hand must be a momentary action.
- 5 The Working Equitation division is comprised of three phases performed in the following order.
  - a. Dressage phase
  - b. Ease of Handling phase
  - c. Speed phase
- 6 Working Equitation is the sum of all phases.
  - a. When a competition includes all phases, the show management may elect to allow entrants to enter one or more of the phases without requiring them to compete in all phases. If show management elects to allow entry in individual phases without requiring participation in all three, competitors

may be awarded placings in each phase separately. However, the overall Working Equitation placings will be limited to competitors who have participated in all three phases. Thus, only competitors who have participated in all three phases will be included in the tallies of rankings to award points for the Working Equitation Competition.

- (1) For example, if six competitors are competing in the Working Equitation Competition, and an additional rider competes in one of the phases and places third in that phase, the competitors placing fourth through seventh in the phase would be moved one place up, third through sixth, for purposes of tallying points for the Working Equitation competition.
- 7 Order of Go: The order of go must be posted at least two hours before each phase begins.
  - a. In the event that the Phases are run back to back without a long break between, the order of go must be posted within 10 minutes of the scheduled first rider. This may require a 10 minute break between phases.
  - b. Order of go shall be determined as follows:
    - (1) Order of go for the Dressage phase will be decided by a draw.
    - (2) The order of go for subsequent phases will be the reverse of the order of placing for the previous phase. (i.e., the highest-placing rider in the dressage phase will ride last in the Ease of Handling phase).
      - (a) In situations where one or more riders are competing in only one or two phases, the order of go for these riders shall be by draw and precede the riders competing in the full competition.
  - c. Competitors who fail to comply with the order of go will be eliminated.
  - d. In the event that during the Ease of Handling or Speed phases, a competitor has horses placed consecutively, he/she will be allowed a 5-minute gate hold to prepare the next horse for the arena.
  - e. If a competitor is affected by a serious, confirmed problem (loss of shoe, injury, etc.), the judge, at his/her discretion, may alter the order of go and shall have such alteration announced to the public.
- 8 Outside Assistance: Competitors may not receive any outside assistance during the phases. Riders are only allowed to receive clarifications or advice during the warm-up period and after the phase has been completed.
  - a. Exception: A caller may be used for the Dressage phase at the Basic level.

### **WE 102 Eligibility**

- 1 Horses must be at least four years of age to be shown at the Basic level and five years of age to be shown at the Intermediate level.
- 2 A horse must compete at the same level for all phases. A horse may not compete with multiple riders. However, a rider may compete on multiple mounts as separate competition entries.
- 3 Horses must be serviceably sound, show no signs of lameness, and be in good condition.
- 4 An entry which shows visible signs of injury caused by excessive use of riding aids, including but not limited to whip, spurs, and bits shall immediately be eliminated. Additionally, schooling, lunging or riding an obviously lame or excessively tired horse will result in elimination. Upon being eliminated, competitors must immediately surrender to show management any awards received in any of the phases of competition which they have previously completed. Such awards will be redistributed.
- 5 Classification:
  - a. Individual Classification-Individual horse and rider combinations must compete in all three required phases, with the scores added to determine the winner.
  - b. Modified Team Classification-Three or fewer horse and rider combinations must compete in all the individual phases. The team with the highest number of combined points will be declared the winner.
- 6 Class Levels: Classes shall be divided into Basic and Intermediate levels.
  - a. Divisions within these levels may be offered for amateur and open divisions.

**WE 103 Tack and Attire**

- 1 Competitors must use consistent tack and attire for all phases.
- 2 The United States of America is known as the melting pot of the world. This is true also regarding the equestrian arts. As such, there are diverse expressions of equestrian traditions in the United States in the working manner of riding. As a reflection of this diversity, these rules allow many styles of tack and attire, provided the tack and attire are fully consistent with some form of traditional tack and attire. Examples of acceptable tack and attire are:
  - a. Traditional tack and attire of the working equestrian of the United States: Though not exclusive, the prevailing working tradition is that of the American cowboy. American cowboy tack and attire in the United States may vary significantly from region to region, and such variations should be recognized and allowed. Where there are regional variations in tack, the turn out should be consistent to a single region. The tack and attire of the USEF WS Western Division rules is an acceptable variant.
  - b. Traditional tack and attire of the working equestrian of the nation of origin of the entry's horse: For example, it would be appropriate for an entry to show in traditional Spanish vaquero tack and attire for an entry with a Spanish, Andalusian, or Half-Andalusian horse.
  - c. Traditional tack and attire of the hunter: Hunter tradition traces back to English fox hunting. The early American settlers established the tradition in the colonies, and it is still maintained in the United States. Tack and attire as defined in the USEF HU Hunter Division Rules is an acceptable variant.
  - d. Traditional tack and attire of Dressage as defined in the USEF DR Dressage Division Rules: The roots of dressage are the military preparation of horse and rider for military field work, common to cavalries the world over.
  - e. Attire of field boots or boots and half chaps, breeches, a polo shirt, and English, Spanish, or Portuguese tack is acceptable for Basic level.
- 3 Regardless of the national tradition of an entry's turnout, at no time shall a horse be shown, exhibited, exercised, or otherwise subjected to tack or other artificial devices that are deemed inhumane, cause visible injury obvious to the judge or steward, or are otherwise prohibited from general use by USEF.
- 4 At no time should an entry exhibit in a mixture of tack or attire from various disciplines, cultures, diverse traditions, or nations. As an example, it would be improper to show in Spanish tack with American attire, or to show in modern tack with historical attire. Violation is grounds for elimination.
- 5 Tack and attire must be complete. Tack and attire are important to the overall impression of an entry, but shall comprise a minor component of the entry's overall impression score. The focus of Working Equitation is on the performance of the horse and rider, not on their appearance.
- 6 Disputes as to the acceptability of an entry's tack or attire may be referred to the judge through the steward prior to the commencement of the competition. Any decision made by the judge shall be final.
- 7 There shall be no penalty for the use of protective headgear or protective safety vest for the rider in any Phase.
- 8 Bell boots (over-reach boots) or similar devices are not allowed, except that in the case of inclement weather, management may permit the use of bell boots on the front hooves for the Ease of Handling and Speed phases only. Shin guards for horses are allowed only in the Speed phase.
- 9 No whips or crops are allowed in competition phases. They may be used in the warm-up arena but may not be taken into the competition arena.

**WE 104 Dressage Phase**

- 1 The object of the Dressage phase is to demonstrate the harmonious development of the physique and ability of the horse. The working equitation horse in this phase should appear calm, supple, loose, flexible, confident, attentive, and keen, thus achieving understanding with its rider. Each movement should be executed smoothly and with precision. These qualities should be demonstrated by:
  - a. Confidence and regularity of movement
  - b. Harmony, lightness, and ease of movement
  - c. Lightness of front end of the horse and engagement of the hind end, demonstrating good impulsion.
  - d. Acceptance of the bit, with total submission and without any tension or resistance.
- 2 The Dressage phase tests are found in WE111 of this document. The riding test corresponding to the level for which the entrant is competing shall be used.
- 3 A single judge is allowed, but a minimum of three judges is recommended, with five preferred. Distribution around the arena shall be as follows:
  - a. 1 judge: The judge should be on the short side of the arena, opposite the entry gate and at center.
  - b. 3 judges: The head judge should be on the short side of the arena, opposite the entry gate and at center. Each of the remaining two judges shall be located on each of the long sides, opposite center.
  - c. 5 judges (preferred): The head judge should be on the short side of the arena, opposite the entry gate and at center. One judge each shall be located on the same side of the arena as the head judge, each located 2.5 meters from the corner of the arena such that one is on either side of the head judge. Each of the remaining two judges shall be located on each of the long sides, opposite center.
- 4 The head judge will signal readiness to judge a test by using a bell or whistle. Upon the judge's signal, the entry shall have one minute to enter the arena and commence the test or be eliminated.
- 5 Evaluation of each entry begins when he/she enters the arena and ends when he/she finishes the test (final salute).
- 6 Salute: Horses will remain at a halt when riders salute the judge. Female riders and male riders wearing protective head gear will salute the judge with a slight nod and sweep of the arm not holding the reins. Male riders not wearing protective headgear will remove their hat using the hand which is not holding the reins.
- 7 Certain movements are valued higher than others and will be assigned a coefficient to increase their impact on overall score, as indicated by the coefficient column in the tests located in the appendix of this document. The final score for such movements is calculated by multiplying the coefficient by the score given by the judge.
- 8 Errors on Course: every error on course must be penalized as follows:
  - a. the first time by 2 points
  - b. the second time by 2 points
  - c. the third time, the entry is eliminated. The judge may permit eliminated entries to finish the test; however, if the entry is about to interfere with the time of the next ride, the entry will be excused.
- 9 Scoring: All movements will be assigned a mark from 10 to 0, using the following scale:
 

• Excellent	10
• Very Good	09
• Good	08
• Reasonably Good	07
• Satisfactory	06
• Marginal	05
• Insufficient	04
• Fairly Bad	03
• Bad	02
• Very Bad	01
• Not executed	00

- a. The marks are then multiplied by the corresponding coefficients listed in the coefficient column of the test form and totaled. Penalty points incurred for errors in the execution of the test are then deducted on the judge's sheet.
- 10 The entry with the highest score shall be declared the winner of the phase. In the event of a tie, the total marks for General Impressions are used to break the tie. In the event that the General Impressions marks are equal, tied entries must remain tied and will each be awarded the points associated with the placing for which they are tied.

### **WE 105 Ease of Handling Phase**

- 1 The objective of this phase is to demonstrate both rider's and horse's capacity for tranquil, precise, and stylish movement through a variety of obstacles representing challenges which could be encountered in the field or which can provide evidence of the rider's clarity and precision and the mutual understanding and harmony between horse and rider.
- 2 A single judge is allowed, but a minimum of three judges is encouraged, with five preferred. Distribution around the arena shall be such that each judge has a clear view of all obstacles, with each judge having a different vantage point than the others.
- 3 The head judge will signal readiness to judge a test by using a bell or whistle. Upon the judge's signal, the entry shall have one minute to enter the arena and commence the test or be eliminated.
- 4 Obstacles should be designed with safety in mind. If at any time an obstacle is found to be unsafe, it shall be repaired or removed from the course. If it cannot be repaired, and some horses have completed the course, the score for this obstacle shall be deducted. No horse shall be asked to repeat the course.
- 5 Each phase shall include obstacles as described below:
  - a. Basic level: A minimum of 7 obstacles and a maximum of 10, chosen from obstacles 1 through 19 described in these rules.
  - b. Intermediate level: A minimum of 10 obstacles and a maximum of 15, chosen from any obstacles described in these rules.
  - c. The judge has the right to alter the course.
- 6 Movement between obstacles shall be:

<b>Level</b>	<b>Gait</b>
Basic	Trot or Canter
Intermediate	Canter

For the Basic level, when in the descriptions of the obstacles the word *canter* is used, this shall mean trot *or* canter, except in the livestock pen obstacle, in which a walk is required of Basic level entries.

- 7 Matrix of Obstacles indicating the allowed gaits for each level: In the table below, each obstacle type is indicated with the gaits allowed for that obstacle. Reference the obstacle descriptions for more information.

<b>OBSTACLE/LEVEL MATRIX with GAIT ALLOWED</b>			
		Gaits Allowed	
#	Obstacle Type	Basic	Int.
	Between Obstacles	T/C	C
1	Gate	N/A	N/A
2	Retrieve Lance	T/C	C
3	Knock Down Balls	T/C	C
4	Hit a Shield	T/C	C
5	Replace Lance	T/C	C
6	Bridge	W	W
7	Livestock Pen	W	C
8	Pitcher of Water	W	W
9	Move a Sack	W	C
10	Hay Jump	T/C	C
11	Pole Bending	T	C
12	Figure 8	T/C	C
13	Corridor/Bell	W	W/C
14	L or Z corridor	W	W/C
15	Cloverleaf	T/C	C
16	Parallel Pole Bending	T	C
17	Move a Ball in Corridor	W	W
18	Dismount	N/A	N/A
19	Unusual Footing	W	W
20	Pole Bending/Reinback		C
21	Sidepass Pole		W/C
22	Hay Jump w/ Corridor		C
23	Water Ditch		C
24	Embankment		C
25	Herding cattle		N/A
26	Pirouette in the Triangle		C

**LEGEND**

- a. N/A – Not applicable. The obstacle does not have a gait associated with it.
- b. W – Walk
- c. T – Trot
- d. C – Canter
- e. When multiple terms are included, separated by a forward slash, the multiple gaits indicated are allowed. For example, W/C means only Walk or Canter are allowed and trotting is not allowed.

- 8 The course must be posted at least two hours before the scheduled start time of the phase.
- 9 All exhibitors entered in the phase will be allowed to inspect the course on foot with the judge and the course designer, if present, prior to the start of the phase. Exhibitors may be accompanied by their trainers.
- 10 All elevated poles must be set in a standard jump cup or similar type bracket.
- 11 The course should be set up in such a manner as to allow the movements to be performed by riders using their left hand to hold the reins.
- 12 All obstacles are marked by red and white flags or markers to denote side of the obstacle (red on the right and white on the left) and numbered on the right hand side of the entrance flag to indicate the order in which they should be completed.
- 13 Competitors must follow course in the manner and order posted. Unless otherwise specified, all obstacles shall be performed at the gait specified for the level being performed. Entries who do not move between obstacles at the specified or faster gait will receive a lower score.
- 14 At the Basic level, riders may enter the riding arena at the trot or the canter. At the Intermediate level, riders shall enter the riding arena at a canter. Show management has the right to alter the entry gait for conditions where a faster gait is deemed unsafe. The riders shall approach the judge and salute. Female competitors and male competitors wearing protective headgear will salute the judge with a slight nod and sweep of their right arm. Male competitors not wearing protective headgear will remove their hat using the hand which is not holding the reins. After the judge has acknowledged the salute, entries may begin negotiating the obstacles.
- 15 In order for an obstacle to be successfully performed, a rider must enter, exit and work the obstacle from the correct side or direction and perform the technical maneuver required by the obstacle.
- 16 Judging criteria general to all obstacles is as follows:
  - a. The phase is judged on the performance of the horse over and through obstacles with emphasis on accuracy through the course, ease of handling, way of going, regularity of movements, quality of canter departures, submission to aids, collection, and harmony of movements.
  - b. Riders are also being assessed on their position in the saddle, subtle use of aids and exclusive use of one hand where the rider has started with one hand for the Intermediate level.
  - c. The horse should work “on the bit,” cadenced, and in balance.
  - d. Continuity of action, and harmony and precision of the horse’s movements are considered.
  - e. Obstacles performed at the canter should always be on the correct lead.
  - f. Change of direction at the canter shall have a corresponding lead change. Flying changes shall be rewarded more than simple changes.
  - g. Lower scores shall be awarded when obstacles are knocked down.
  - h. Except where specifically noted in the obstacle descriptions, if, after 20 seconds of approaching an obstacle, the horse and rider have not entered the obstacle, the judge should instruct them to move on to the next obstacle. The judge shall give a zero score for the obstacle. This will not be considered a cause for elimination.
  - i. If a competitor commits an error within any obstacle, the competitor may re-start the obstacle and perform it correctly. Credit shall be given for the proper execution with a deduction for the error.

17 Scoring: Execution of all obstacles, Notes for the Course, and Overall Impression will be rated from 10 to 0 on the score sheet, using the following scale:

• Excellent	10
• Very Good	09
• Good	08
• Reasonably Good	07
• Satisfactory	06
• Marginal	05
• Insufficient	04
• Fairly Bad	03
• Bad	02
• Very Bad	01
• Not Executed	00

18 The entry with the highest score shall be declared the winner of the phase. In the event of a tie, the total marks for General Impressions are used to break the tie. In the event that the General Impressions marks are equal, tied entries must remain tied and will each be awarded the points associated with the placing for which they are tied.

19 Elimination – Causes for elimination in the Ease of Handling phase shall include:

- a. Failure to halt and salute the head judge or beginning the course before acknowledgement from the judge.
- b. Committing a Course Error - Course errors include:
  - (1) Approaching, crossing through, or over an obstacle out of sequence.
    - (a) Exceptions may be made for obstacle types 2, 3, 5 (lance ball/ring combination), obstacle types 11, 16, and 20 (pole bending), and obstacle type 9 (move a sack). If exceptions are allowed, this must be noted on the course map and explained to the competitors during the walk through of the course.
  - (2) Skipping an obstacle unless directed to do so by the judge.
  - (3) Executing an obstacle incorrectly. This shall be determined by the judge.
  - (4) Entering/exiting on the wrong side of the flags denoting right/left shall be considered incorrect execution.
  - (5) Failure to correct an error within an obstacle (see section WE105.17.i) before moving on to the next obstacle, without being instructed by the judge to do so.

20 Obstacles and their Execution:

a. Obstacle Type 1: **GATE**

(1) Construction:

- (a) The gate is to be constructed such that the top of the gate is a minimum of 1.3 meters (4'-3") above the ground, and with 2 meters (6 ½ feet) between gate posts. The gate should swing on two hinges and have a latch constructed of stiff rope or stiff and heavy-gauge wire.

(b) The gate may open either to the left or right, in conformity to the layout of the course. Flags shall denote the approach.

(c) Gate shall provide a visual barrier. Large pickets or wide rails on a frame, all constructed of wood and wood posts are examples of such construction.

- i A rope with a loop on the opening end may be used in lieu of a solid constructed gate for Basic level, and for the speed test for all levels. The rope length shall ensure that the drape of the rope does not exceed 6 inches.

#### KEY TO DIAGRAMS

ADVANCE ▲

REIN BACK ▼

FLYING CHANGE ✕

## (2) Execution

- (a) Horse and rider canter up close to the obstacle and make their final approach at the walk. The horse's approach shall exhibit a high level of confidence.
- (b) Horse and rider position themselves at the side of the gate, to the left or right, depending upon opening direction.
- (c) Riders shall use their right hand to lift up the latch, and horse and rider shall open the gate and walk through it. Competitors in the Intermediate level shall also close the gate from the exit side and return the latch to the gate post. The horse and rider may back up to close the gate. The rider's hand shall stay in contact with the gate at all times. In the Basic level, the horse and rider must clear the gate before releasing the gate.

## (3) Scoring

- (a) The judge shall rate the horse's action for:
  - i Fluidity;
  - ii Lack of hesitation;
  - iii Awareness and participation in the opening and closing actions;
  - iv Obedience, confidence, and trust in the rider.
- (b) The judge shall rate the rider's action for:
  - i Precision;
  - ii Lack of hesitation;
  - iii Use of aids to encourage the horse's movement, as necessary.
- (c) Penalties shall be incurred for:
  - i Rider letting go of gate while performing the opening/closing operations;
  - ii Insecurity exhibited by the horse or rider;
  - iii Lack of continuity of action.

b. Obstacle Type 2: **RETRIEVE A LANCE FROM A BARREL**

## (1) Construction:

- (a) One open top, well-balanced barrel.
- (b) Wooden lance, length between 3 and 4 meters (10 and 13 feet).

## (2) Execution

- (a) Horse and rider approach the barrel at a canter and retrieve the lance with their right hand while encircling the barrel.
- (b) This obstacle is used in conjunction with obstacle types 3, 4, 5, and 17 and is first in sequence. When obstacle type 2 is included in an obstacle phase, obstacle type 5 must also be included. Obstacle types 3, 4, and 17 are not required to be included in an obstacle phase when obstacle type 2 is included. Additionally, for the Intermediate level, any other obstacle may be placed between obstacle type 2 and 5 (i.e., the rider continues to ride with the lance while encountering the additional obstacles).

## (3) Scoring

- (a) The judge shall rate for:
  - i Horse's confidence in approaching the obstacle;
  - ii Horse's reaction to the movement of the lance;
  - iii Relaxed manner of rider in use of the lance.
  - iv Obedience and trust in the rider.
- (b) Penalties shall be incurred for:
  - i Hesitation or break of gait (i.e., falling into walk or trot);
  - ii Knocking the barrel should be heavily penalized.

- iii Dropping of the lance: The rider must dismount, and remount with the lance before continuing the course. Failure to dismount and retrieve the lance will result in elimination.

c. Obstacle Type 3: **KNOCK DOWN BALLS AND/OR CATCH A RING AT VARIOUS HEIGHTS**

(1) Construction:

- (a) Bases to support balls and/or rings. The bases shall be of varying heights between 30 cm. and 1.5 meters (12 and 60 inches). Bases should not be so large as to extend significantly beyond the ball or ring installed on them.
- (b) Wooden lance, length between 3 and 4 meters (10 and 13 feet).
- (c) Ball need not exclusively be spherical, but may include other shapes (e.g., American football). Spherical balls shall be sized in accordance with the table below. The longest dimension of non-spherical balls shall not exceed 1.5 times the largest permissible spherical diameter.
- (d) Metal rings shall have an inside diameter in accordance with the table below.

Level	Diameter of Balls	Inside Diameter of Rings
Basic	$\geq 22.5 \text{ cm (9")} \leq 30 \text{ cm (12")}$	N/A
Intermediate	$\geq 15 \text{ cm (6")} \leq 22.5 \text{ cm (9")}$	$\geq 15 \text{ cm (6")} \leq 22.5 \text{ cm (9")}$

(2) Execution

- (a) Rider shall knock down balls with the tip of the lance or skewer the rings with the lance.
- (b) This obstacle is used in conjunction with obstacle types 2 and 5 and is placed between those obstacles.
- (c) Gait at which the obstacle shall be performed is indicated in the table below.

Level	Gait
Basic	Trot or Canter
Intermediate	Canter

(3) Scoring

- (a) The judge shall rate for:
  - i Natural and relaxed manner of going;
  - ii Precision and execution of the movement;
  - iii At the Basic level, more points shall be given when performed at a faster gait.
- (b) Penalties shall be incurred for:
  - i Break of gait or variation of speed within the gait;
  - ii Hitting the obstacle base, whether or not the ball is knocked down or ring skewered;
  - iii Knocking the base over;
  - iv Dropping the lance: If the lance is dropped, the rider must dismount and remount with the lance before continuing the course. Failure to dismount and retrieve the lance will result in elimination.

d. Obstacle Type 4: **HIT A SHIELD**

(1) Construction:

- (a) This obstacle includes a base supporting a T arm, with shields mounted at either side of the cross-bar of the T arm. The base should be 195 cm (76 inches) square maximum at the bottom, and 50 cm. (20 inches) high, tapering to the top with a hole to accept the T arm

shaft. The T arm should be 228 cm (90 inches) above the base for a total height above the ground of 278 cm (110 inches). The T arm should be 297 cm (120 inches) wide and centered over the shaft. At the ends of the arm are shields approximately 15 cm (6 inches) in diameter, or a shape circumscribed about a circle of the same diameter. The T arm should freely rotate in the base.

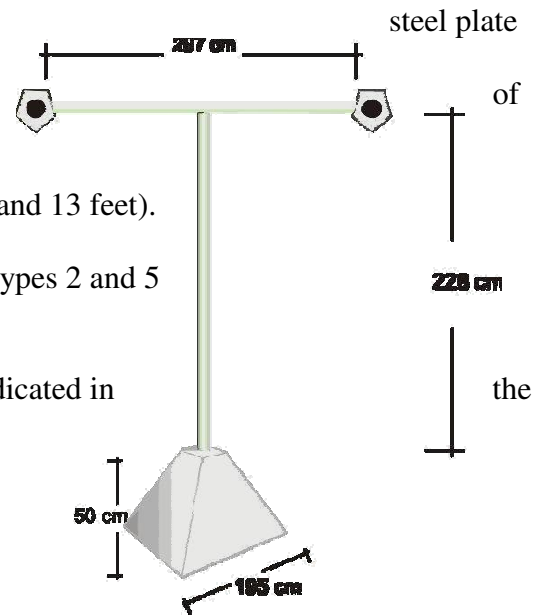

(b) Wooden lance, length between 3 and 4 meters (10 and 13 feet).

(2) Execution

- (a) This obstacle is used in conjunction with obstacle types 2 and 5 and is placed between those obstacles.
- (b) Rider shall knock shield with the tip of the lance.
- (c) Gait at which the obstacle shall be performed is indicated in table below.

Level	Gait
Basic	Trot or Canter
Intermediate	Canter

(3) Scoring

- (a) The judge shall rate for:
  - i Natural and relaxed manner of going;
  - ii Precision and execution of the movement;
  - iii At the Basic level, more points shall be given when performed at a faster gait.
- (b) Penalties shall be incurred for:
  - i Break of gait or variation of speed within the gait;
  - ii Hitting any part of the obstacle except the shield;
  - iii Knocking the obstacle over;
  - iv Dropping the lance: If the lance is dropped, the rider must dismount, and remount with the lance before continuing the course. Failure to dismount and retrieve the lance will result in elimination.

e. Obstacle Type 5: **DEPOSIT A LANCE IN A BARREL**

(1) Construction:

- (a) One open top, well-balanced barrel.
- (b) Wooden lance, length between 3 and 4 meters (10 and 13 feet).

(2) Execution

- (a) Horse and rider approach the barrel at a canter and deposit the lance with the right hand, butt end down, while encircling the barrel.
- (b) This obstacle is used in conjunction with obstacle types 2, 3, 4, and 17 and is last in sequence of those obstacles. When obstacle type 5 is included in an obstacle phase, the obstacle type 2 must also be included. Obstacle types 3, 4, and 17 are not required to be included in an obstacle phase when obstacle type 5 is included.

(3) Scoring

- (a) The judge shall rate for:
  - i Horse's confidence in approaching the obstacle;
  - ii Horse's reaction to the movement of the lance;
  - iii Relaxed manner of rider in use of the lance;
  - iv Obedience and trust in the rider.

- (b) Penalties shall be incurred for:
- i Hesitation or break of gait (i.e., falling into walk or trot);
  - ii Knocking the barrel over;
  - iii Failure of the lance to stay in the barrel after being placed there by rider (e.g., lance bounces out).
  - iv Dropping of the lance: The rider must dismount, and remount with the lance before continuing the course. Failure to dismount and retrieve the lance will result in elimination.
- f. Obstacle Type 6: **BRIDGE**
- (1) Construction:
- (a) The bridge should be made of wood and of solid construction so as to not pose a danger for the horse or rider.
  - (b) Minimum width: 1.5 meters (5 feet); Minimum length: 3 meters (10 feet);
  - (c) The bridge shall rise from flush with the ground on either end to a minimum height at center of 20 cm (8 inches).
  - (d) Rails shall be affixed to both sides of the bridge and shall be a minimum of 30 cm. (12 inches) and a maximum of 1.2 meters (4 feet) in height.
- (2) Execution
- (a) Horse and rider approach the bridge at a canter and transition to the walk before touching the bridge.
  - (b) Horse must cross the bridge at a walk.
  - (c) This obstacle may be used twice in a phase if approached from the opposite end on the second encounter. There must be at least one obstacle between uses of the bridge as an obstacle.
- (3) Scoring
- (a) The judge shall rate for:
    - i Regularity of the walk;
    - ii Confidence;
    - iii Transitions.
  - (b) Penalties shall be incurred for:
    - i Hesitation or uneasiness in crossing the bridge.
- g. Obstacle Type 7: **LIVESTOCK PEN**
- (1) Construction:
- (a) This obstacle shall consist of an inner pen enclosure and an outer barrier with an opening to allow passage.
  - (b) The inner pen shall have a diameter of about 3 meters (10 feet). The height of the inner pen enclosure shall be between 1.2 and 2 meters (4 and 6.5 feet). The pen is designed to contain a small number of livestock (e.g., hens, geese, ducks, goats, sheep, calves, etc.) Where use of live animals is not practical, life-size statuary representing such animals is acceptable.
  - (c) The outer barrier shall be 1.5 meters (5 feet) away from and encircling the inner pen. The height of the outer enclosure shall be between 30 cm. and 1.2 meters. (12 inches and 4 feet). There shall be an opening in the outer enclosure that is 1.5 meters (5

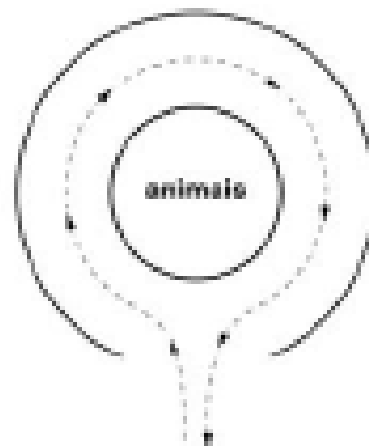

feet) in width to enable competitors to enter the obstacle.

(2) Execution

- (a) Horse and rider approach the pen at a canter. Specified gait for negotiating the obstacle shall be:

Level	Gait
Basic	Walk
Intermediate	Canter

- (b) Competitors shall make one circuit of the obstacle in one direction (course designer may indicate the initial direction), then exit the obstacle, change direction, and return to the obstacle to repeat the circuit in the opposite direction. When changing direction, the horse and rider shall execute a full turn, and the horse shall change lead if cantering.

(3) Scoring

- (a) The judge shall rate for:
- i Serenity and confidence of the horse;
  - ii Calmness of the rider;
  - iii Rider's subtle use of aids.
- (b) Penalties shall be incurred for:
- i Trotting anywhere within the circle of the obstacle;
  - ii Spooking at the livestock;
  - iii Breaking of gait;

h. Obstacle Type 8: **PICK UP A PITCHER OF WATER**

(1) Construction:

- (a) One square table, between 100 cm (39 inches) and 120 cm. (4 feet) high and square. A manufactured table is not required if a table-like platform is constructed of common materials (e.g., hay bales, sacks of grain, etc.)
- (b) Pitcher of water with handle.
- (c) Drinking cup for Intermediate level.

(2) Execution

- (a) Horse and rider shall slow to a walk before entering the obstacle and halt to the side of the table.
- (b) Rider shall perform the following actions:

Level	Action
Basic	Raise the pitcher above the rider's head, then replace pitcher on table.
Intermediate	Raise the pitcher above the rider's head, pour some water into the cup, replace pitcher on table, raise and drink from the cup, then replace the cup on the table.

- (c) Horse and rider shall exit the obstacle at the walk before resuming the gait between obstacles.

(3) Scoring

- (a) The judge shall rate for:
- i Manner of approach to the table and steadiness at the halt;
  - ii Horse's lack of fear and trust in the rider.
- (b) Penalties shall be incurred for:
- i Horse's refusal to remain at the halt;

- ii Spilling of water;
- iii Dropping the pitcher;
- iv Horse knocking the table. If the pitcher and water are knocked off the table, a larger penalty should be given than if the table is knocked but the pitcher remains in place.

i. Obstacle Type 9: **MOVE A SACK**

(1) Construction:

- (a) Two square tables, each between 90 cm. (3 feet) and 120 cm. (4 feet) high and square. A manufactured table is not required if a table like platform is constructed of common materials (e.g., hay bales, sacks of grain, etc.)
- (b) A fabric sack containing items not to exceed 4.5 kilograms (10 pounds).

(2) Execution

- (a) Horse and rider shall approach the table at the gait between obstacles specified for the level in which they are competing.
- (b) Rider shall perform the following actions:

Level	Action
Basic	Slow to a walk before the obstacle. Pick up the sack while walking and continue to the next table. Halt alongside the second table and place the sack on the table. Walk clear of the obstacle and resume gait to the next obstacle.
Intermediate	Maintain the canter until alongside the table. Halt and pick up the sack. Resume the canter and halt alongside the second table. Place sack on second table. Walk clear of the obstacle and resume gait to the next obstacle.

(3) Scoring

- (a) The judge shall rate for:
  - i Manner of approach to the tables and steadiness at the halt;
  - ii Horse's lack of fear and trust in the rider.
- (b) Penalties shall be incurred for:
  - i Horse's refusal to remain at the halt;
  - ii Dropping the sack;
  - iii Horse knocking the table. If the sack is knocked off the table, a larger penalty should be given than if the table is knocked but the sack remains in place.

j. Obstacle Type 10: **HAY BALE JUMP**

(1) Construction:

- (a) Three hay bales laid flat, end to end 3.7 meters (12 feet) long and the height of a hay bale (+/- 16-18") laid on its long side so that they form a jump;
  - i At the Basic level, this obstacle consists of a single rail jump set 12 inches high, bales shall not be used.
- (b) Two jump standards, one at each end of the hay bales;
- (c) Jump pole set in jump cups at the height indicated in table below.

Level	# of poles	Height of upper pole
Basic	Single	30 cm (12")
Intermediate	Single	Just above bales

- (2) Execution
  - (a) Horse and rider jump the obstacle naturally and with assurance.
  - (b) Gait: Trot or canter at Basic level, canter at Intermediate level.
- (3) Scoring
  - (a) The judge shall score for:
    - i Horse’s jumping style;
    - ii Rider’s serenity and use of aids.
  - (b) Penalties shall be incurred for:
    - i Knocking down the jump pole;

k. Obstacle Type 11: **POLE BENDING**

- (1) Construction:
  - (a) Four to six vertical poles, 2 meters (6 ½ feet) in height.
  - (b) Poles shall be spaced 6 meters (20 feet) apart from adjacent poles and in a straight line.
  - (c) Poles shall be set on a base, not sunk into the ground, to allow for give in the event a horse contacts the pole.
  - (d) Flags indicating side of entry shall be placed on each pole.

(2) Execution

- (a) Horse and rider shall approach the obstacle at a canter and perform the obstacle at the gait indicated in the table below;
- (b) Each change of direction, with lead change, should be done halfway between poles. Lead should always be in conformity with the turn. Type of change shall be as indicated in table below.

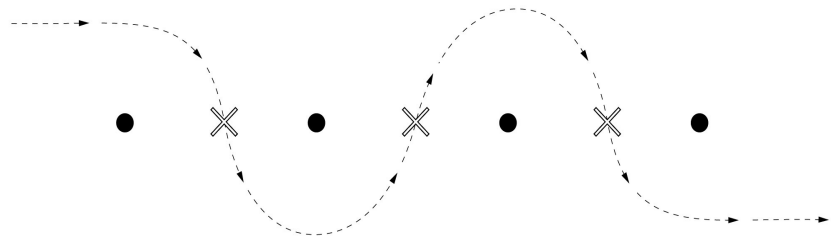

Level	Gait	Change of Lead at Canter
Basic	Trot	N/A
Intermediate	Canter	Flying

(3) Scoring

- (a) The judge shall score for:
  - i Change of lead: More points should be awarded for a properly-executed flying change.
  - ii Rider’s seat and use of aids.
  - iii Fluidity and continuity of movement through the obstacle.
  - iv Horse’s response to the aids and way of going.
- (b) Penalties shall be incurred for:
  - i Breaking of gait;
  - ii Change of lead at other than the midpoint between the poles;
  - iii Failure to change lead;
  - iv Knocking over parts of the obstacle;

1. Obstacle Type 12: **FIGURE 8 AROUND TWO BARRELS**

## (1) Construction:

- (a) Two barrels spaced 3 meters (10 feet) apart.

## (2) Execution

- (a) Horse and rider shall approach the obstacle at a canter and perform the obstacle at the gait indicated below.
- (b) The horse and rider shall perform a circle around the right hand barrel, diameter as indicated below.
- (c) Upon completing the turn, halfway between the barrels, the horse shall change lead, type of change indicated below, and begin a circle of the same diameter around the left hand barrel.
- (d) Upon completion of the second circle, the horse and rider shall pass half way between the barrels and exit the obstacle.

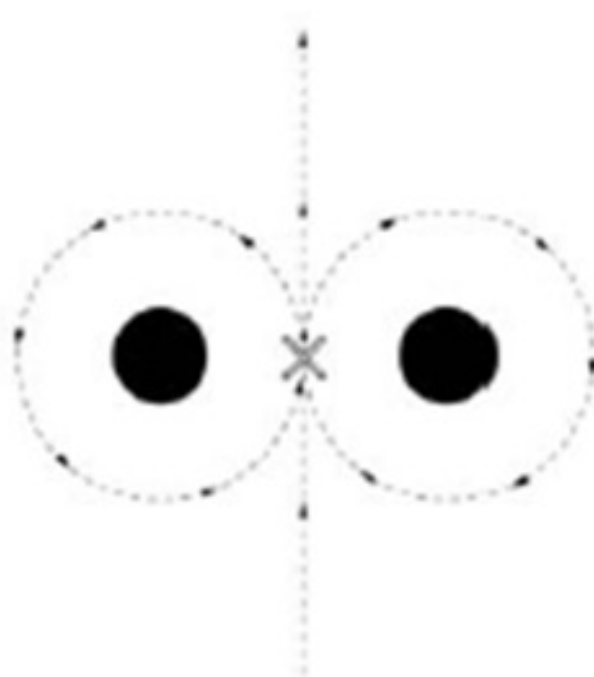

Level	Gait	Max. diameter of Circle	Change of Lead at Canter
Basic	Trot or Canter	6 meters (20 feet)	Simple
Intermediate	Canter	3 meters (10 feet)	Flying

## (3) Scoring

- (a) The judge shall rate for:
- i Precision, shape, and symmetry of the circles;
  - ii Change of lead: may be simple change or flying change. More points should be awarded for a properly-executed flying change.
  - iii Horse's response to the aids and action.
- (b) Penalties shall be incurred for:
- i Breaking of gait;
  - ii Change of lead at other than the midpoint between the barrels;
  - iii Failure to change lead;
  - iv Knocking over parts of the obstacle.

m. Obstacle Type 13: **RING A BELL AT THE END OF A CORRIDOR**

## (1) Construction:

- (a) The corridor shall be 3.7 meters (12 feet) long and consist of poles resting on supports, small fences, or walls. Height of poles, fences, or walls shall be at least 30 cm. (12 inches). They shall be placed parallel to one another and spaced a distance of 1.2 meters (4 feet) apart.
- (b) Post between 1.5 and 2 meters (5-6 ½ feet) high. The post is to be located at the end of the corridor adjacent to the elevated pole, fence, or wall on the right.

- (c) Bell mounted to top of post.
  - i Alternate to bell on single post: Two posts between 1.5 and 1.8 meters (5-6 feet) high located one each at the right side of the entry and end or at either side of the end. One cup atop the right-most post at the end.

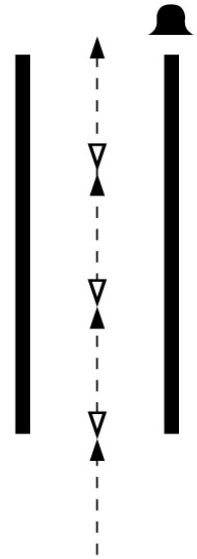

- (2) Execution
  - (a) Gait performed in corridor shall be:

Level	Gait	Rein back Required?
Basic	Walk	Yes
Intermediate	Walk or Canter	Yes

- (b) The horse and rider shall proceed to the end of the corridor and halt. Rider shall ring bell with the right hand.
  - i If the cup alternate is used, the competitor shall transfer the cup from one post to the other, either to the side or at the end of the rein back according to the obstacle design.
- (c) Riders shall rein back to the entrance of the corridor and exit behind and to the side of the obstacle.

(3) Scoring

- (a) The judge shall rate for:
  - i Horse’s attitude and collection;
  - ii Rider’s use of aids;
  - iii Speed, fluidity, continuity, and precision of execution.
- (b) Penalties shall be incurred for:
  - i Horse contacting the elevated poles.
  - ii Failure to ring the bell, or move the cup if that alternative is used, will result in a zero score for the obstacle.

n. Obstacle Type 14: **THE “L” OR “Z” CORRIDOR**

(1) Construction:

- (a) 2.5 and 3.7 meter (8 and 12 feet) poles elevated on supports, small fences, or walls. Height shall be minimum 30 cm. (12 inches) from the ground. Poles, fences, or walls shall be arranged in either an “L” or “Z” pattern and set 1.2 meters (4 feet) apart to create a corridor.
- (b) Post between 1.5 and 2 meters (5-6 ½ feet) high. The post is to be located at the end of the corridor adjacent to the elevated pole, fence, or wall on the right.
- (c) Bell mounted to top of post.
  - i Alternate to bell on single post: Two posts between 1.5 and 1.8 meters (5-6 feet) high located one each at the right side of the entry and end or at either side of the end. One cup atop the right most post at the end.

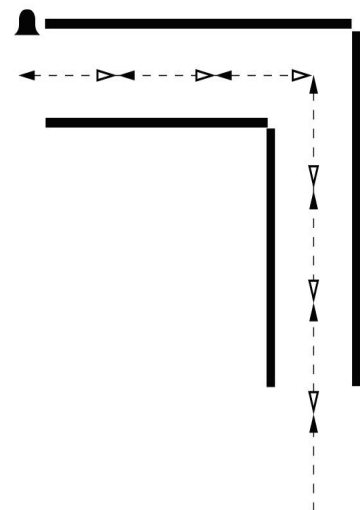

## (2) Execution

(a) Gait performed in corridor shall be:

Level	Gait	Rein back Required?
Basic	Walk	No
Intermediate	Walk or Canter	Yes

(b) Horse and rider enter the corridor and proceed to the end where they shall halt.

(c) Rider shall ring bell with the right hand.

i If the cup alternate is used, the competitor shall transfer the cup from one post to the other, either to the side or at the end of the rein back, according to the obstacle design.

(d) For Intermediate level, rider shall rein back through the entire obstacle and exit at the entry.

(e) For the Intermediate level, a lower score should be awarded for the walk than the canter.

## (3) Scoring

(a) The judge shall rate for:

i Horse's fluidity of movement and response to rider's aids;

ii Rider's use of aids.

(b) Penalties shall be incurred for:

i Failure of the horse to remain at the halt during ringing of bell or retrieving/replacement of cup.

ii Failure to ring bell, or move the cup if that alternative is used, will result in elimination zero score for the obstacle.

o. Obstacle Type 15: **CLOVERLEAF AROUND THREE BARRELS**

## (1) Construction:

(a) Three barrels spaced 3 meters (10 feet) apart in triangular form.

## (2) Execution

(a) Horse and rider shall approach the obstacle at a canter and perform at the gait indicated in the table below.

(b) The horse and rider enter between the barrels to the side indicated by the flags. They shall perform a circle around the first barrel indicated by the course map.

(c) Upon completing a full circuit around the barrel, at the point of crossing an imaginary line between the first barrel and the second barrel, located at the point halfway between the barrels, the horse shall change lead and begin a circle of the same diameter around the second barrel.

(d) Upon completion of the circuit of the second barrel, and at the point of crossing an imaginary line between the second barrel and the remaining barrel, the horse shall change lead and begin a circle of the same diameter around the third and final barrel.

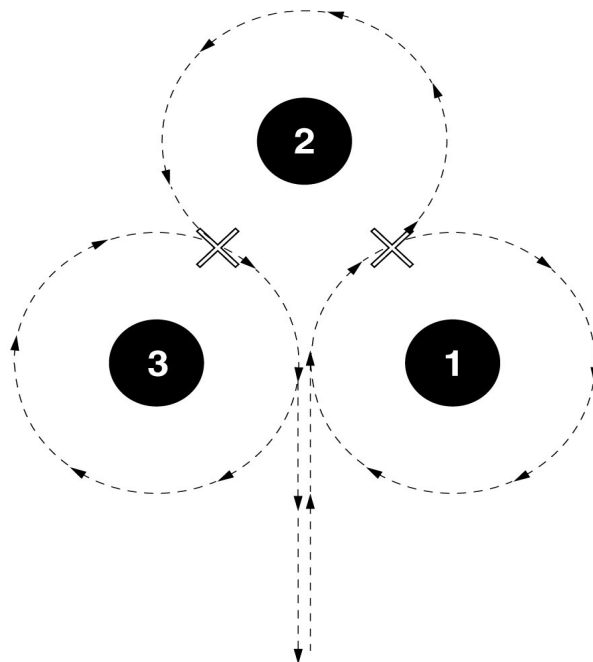

- (e) Upon completing a full circuit around the third barrel, the horse and rider shall pass half way between the first and third barrels to exit the obstacle.

Level	Gait	Diameter of Circle	Change of Lead at Canter
Basic	Trot or Canter	4.5 meters (15 feet)	Simple
Intermediate	Canter	3 meters (10 feet)	Flying

(3) Scoring

- (a) The judge shall rate for:
- Precision, shape, and symmetry of the circles;
  - Change of lead: may be simple change or flying change. More points should be awarded for a properly-executed flying change.
  - Horse's response to the aids and quality of movement.
- (b) Penalties shall be incurred for:
- Breaking of gait;
  - Change of lead at other than the midpoint between the barrels;
  - Failure to change lead;
  - Knocking over parts of the obstacle;

p. Obstacle Type 16: **PARALLEL POLE BENDING**

(1) Construction:

- Minimum of seven vertical poles of 2 meters (6 ½ feet) height.
- The poles shall be arranged in two parallel lines with a distance of 6 meters (20 feet) between the lines. The poles within each line shall be spaced 6 meters (20 feet) apart from adjacent poles within the line. The lines shall be staggered equally so that the first even-numbered pole is set opposite the midpoint between the first and second odd-numbered pole.
- Poles shall be set on a base, not sunk into the ground, to allow for give in the event a horse contacts the pole.
- Flags indicating side of entry shall be placed on each pole.

(2) Execution

- Horse and rider shall approach the obstacle at a canter and perform the obstacle at the gait indicated in the table below;
- Each change of direction, with lead change, should be done halfway between poles. Lead should always conform with the direction of the turn. Type of change shall be as indicated in the table below;

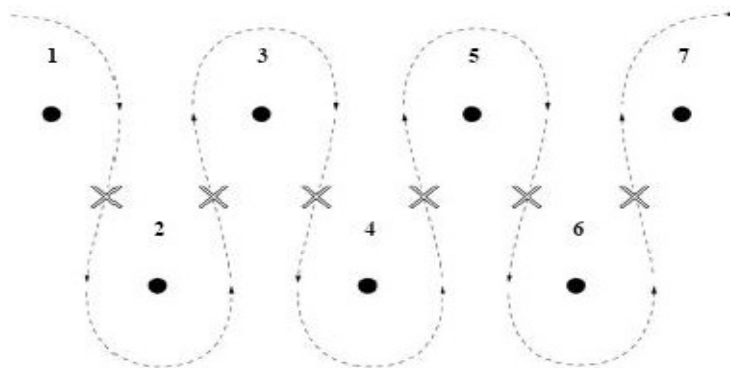

Level	Gait	Change of lead at Canter
Basic	Trot	N/A
Intermediate	Canter	Flying

- (c) This obstacle may be performed at the walk, but a lower score should be awarded for the walk than the trot or canter.

## (3) Scoring

- (a) The judge shall score for:
  - i Change of lead: more points should be awarded for a properly-executed flying change.
  - ii Rider's seat and use of aids.
  - iii Fluidity and continuity of movement through the obstacle.
  - iv Horse's response to the aids and way of going.
- (b) Penalties shall be incurred for:
  - i Breaking of gait;
  - ii Change of lead at other than the midpoint between the poles;
  - iii Failure to change lead;
  - iv Knocking over parts of the obstacle;

q. Obstacle Type 17: **MOVE A BALL IN A CORRIDOR**

## (1) Construction:

- (a) The corridor shall be 3.7 meters (12 feet) long and consist of small fences at least 30 cm. (12 inches) in height. The long sides of the corridor shall be parallel to one another and spaced a distance of 1.8 meters (6 feet) apart. One end shall be open and the other closed by a small fence of similar construction.
- (b) Ball, size as indicated in table below.

Level	Diameter of Ball
Basic	$\geq 30$ cm (12") $\leq 45$ cm (18")
Intermediate	$\leq 22.5$ cm (9")

## (2) Execution

- (a) This obstacle is used in conjunction with obstacle types 2 and 5 and is placed between those obstacles.
- (b) The horse and rider shall proceed to the open end of the corridor where the ball is placed. Rider shall guide ball in a controlled manner by using the lance until the ball touches the closed end of the corridor.
- (c) If the ball leaves the corridor before touching the end, rider must exit corridor by reining back, recollect the ball and guide it back into and through the corridor until the ball touches the end of the corridor.
- (d) After the ball touches the end of the corridor, the rider shall rein back to exit the obstacle.

## (3) Scoring

- (a) The judge shall rate for:
  - i Horse's attitude and collection;
  - ii Rider's use of aids;
  - iii Speed, fluidity, continuity, and precision of execution.
  - iv More points shall be awarded for the rider guiding the ball to the end of the corridor without the ball touching the sides of the corridor.
- (b) Penalties shall be incurred for:
  - i Horse contacting the fences.
  - ii Ball leaving the corridor.
  - iii Knocking down any part of the obstacle.

r. Obstacle Type 18: **DISMOUNT, WALK AROUND HORSE, AND REMOUNT**

## (1) Construction:

- (a) A mounting block is optional.

## (2) Execution

- (a) The horse shall canter to the point of the obstacle and halt.
- (b) The rider shall dismount and walk a full circle around the horse, maintaining a minimum of 3 meters (10 feet) away from the horse. The rider may not hold the reins or touch the horse during the course of the circle. If the rider must take hold of the reins or touch the horse, he/she must re-start the circle.
- (c) Upon completion of the circle, the rider shall mount the horse.

## (3) Scoring

- (a) The judge shall rate for:
  - i Horse's calmness;
  - ii Horse remaining stationary;
  - iii Ease of re-mounting.
- (b) Penalties shall be incurred for:
  - i Excessive movement of the horse;
  - ii If the horse leaves the area of the obstacle, the rider must retrieve the horse and return to the point of the obstacle and finish the obstacle. If he/she does not, the competitor is eliminated.

s. Obstacle Type 19: **RESERVED**t. Obstacle Type 20: **POLE BENDING WITH REIN BACK**

## (1) Construction:

- (a) Three or five vertical poles, each 2 meters (6 ½ feet) in height.
- (b) Poles shall be spaced 6 meters (20 feet) apart from adjacent poles and in a straight line.
- (c) Poles shall be set on a base, not sunk into the ground, to allow for give in the event a horse contacts the pole. (See diagram at obstacle type 13)
- (d) Flags indicating side of entry shall be placed on each pole.
- (e) One cup, placed upside down atop the final pole.

## (2) Execution

- (a) Horse and rider shall approach the obstacle at a canter and maintain and perform the obstacle at the gait indicated in the table below;
- (b) Each change of direction, with lead change, should be done halfway between poles. Lead should always conform with the direction of the turn. Type of lead change shall be as indicated in table below;
- (c) The horse and rider shall halt next to the final pole. Riders shall retrieve the cup with their right hand.
- (d) The horse and rider shall rein back to the entry of the obstacle and place the cup, upside down, on top of the first pole. Rein back shall be as indicated in table below.

Level	Gait	Change of lead at Canter	Rein back
Intermediate	Canter	Flying	Straight

## (3) Scoring

- (a) The judge shall score for:
  - i Change of lead: may be simple change or flying change. More points should be awarded for a properly-executed flying change.
  - ii Rider's seat and use of aids.
  - iii Fluidity and continuity of movement through the obstacle.
  - iv Horse's response to the aids and action.

- (b) Penalties shall be incurred for:
  - i Breaking of gait;
  - ii Change of lead at other than the midpoint between the poles;
  - iii Failure to change lead;
  - iv Knocking over any part of the obstacle;
  - v Failure to retrieve or replace the cup will result in a zero score for the obstacle.

u. Obstacle Type 21: **SIDEPASS POLE**

(1) Construction:

- (a) One or more 3.7 meters (12 feet) poles supported 5 cm. (2 inches) above the ground. Poles may be arranged in the following manners and performed in the levels as described in the table below.
  - i Single pole;
  - ii Two parallel poles separated by 3 meters (10 feet);
  - iii Two poles in an L configuration;
  - iv Three poles in a Z configuration.

Level	Pole Configuration
Intermediate	Single or Parallel poles or L configuration.

(2) Execution

- (a) The horse shall exercise lateral/half pass movement along the length of the obstacle.
- (b) The pole(s) shall remain between the horse's front and back legs throughout the obstacle.
- (c) This obstacle may be performed at the walk, but a lower score should be awarded for the walk than the canter.



(3) Scoring

- (a) The judge shall rate for:
  - i Horse's capacity to perform the obstacle;
  - ii Horse's fluidity of movement and response to rider's aids;
  - iii Horse's confidence;
  - iv Rider's use of aids.
  - v More points shall be given for executing the obstacle at the canter than the walk.
- (b) Penalties shall be incurred for:
  - i Horse touching the pole(s);
  - ii Horse knocking over the pole(s);
  - iii Any leg stepping across the rail while negotiating the obstacle.

v. Obstacle Type 22: **HAY BALE JUMP WITH A CORRIDOR**

(1) Construction:

- (a) Three hay bales laid flat, end to end so they make a jump approximately 3.7 meters (12 feet) wide; Natural elements such as low bushes or flowers may be used in lieu of hay bales, but they must not exceed the height of a hay bale, approximately 50 cm (20 inches);

- (b) Two jump standards, one at each end of the hay bales;
  - (c) Jump pole set in jump cups at a height just above the hay bales;
  - (d) 5 meters (16 feet) of ground rail on either side of jump exit and in the direction of travel away from the jump.
- (2) Execution
- (a) Horse and rider jump the obstacle naturally and with assurance.
- (3) Scoring
- (a) The judge shall score for:
    - i Horse's jumping style;
    - ii Rider's calmness and use of aids.
  - (b) Penalties shall be incurred for:
    - i Knocking down a jump pole.

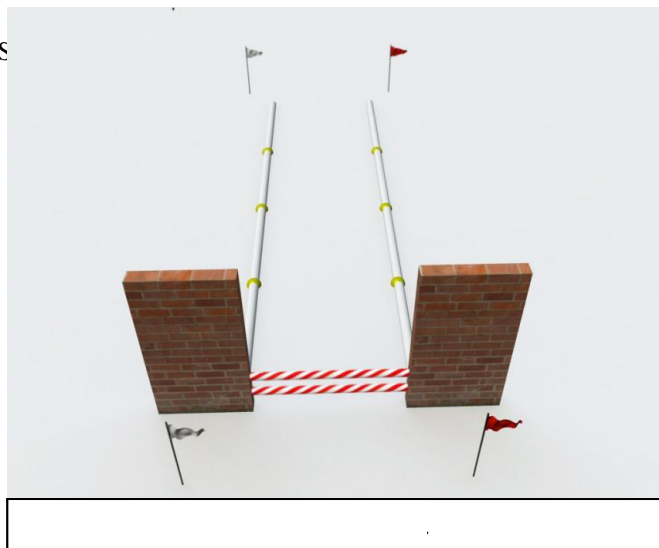

- w. Obstacle Type 23: **RESERVED**
- x. Obstacle Type 24: **RESERVED**
- y. Obstacle Type 25: **RESERVED**
- z. Obstacle Type 26: **PIROUETTE IN THE TRIANGLE**

- (1) Construction:
- (a) Three 3 meter (10 foot) poles arranged in an equilateral triangle on the ground.
- (2) Execution
- (a) The horse shall canter into the triangle with the red flag on the rider's right hand side.
  - (b) Once inside the triangle, the horse and rider shall perform a  $\frac{3}{4}$  pirouette toward the direction indicated by the course design, leaving the triangle at the adjacent opposite side and changing lead upon exit.
- (3) Scoring
- (a) The judge shall score for:
    - i Rider's relaxed attitude during the obstacle;
    - ii Accuracy of the  $\frac{3}{4}$  pirouette;
    - iii Placement of the pirouette being centered in the triangle;
    - iv Lead change may be either a flying change or a simple change. More points shall be awarded for a flying change.
  - (b) Penalties shall be incurred for:
    - i Hesitation of the horse.

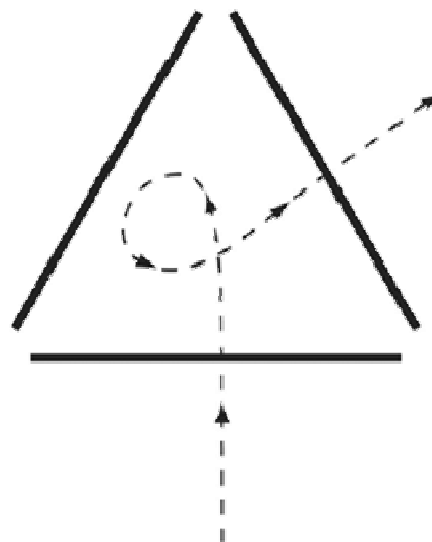

aa. ADDITIONAL OBSTACLES

- (1) Additional obstacles may be added at the discretion of the competition management provided they are in the spirit of using obstacles to demonstrate the horse and rider's abilities in a

working environment. Any additional obstacles must be explained in full during the walk through of the course.

### **WE 106 Speed Trial Phase-Speed through obstacles**

- 1 The speed trial has been designed to demonstrate the rider's capacity for coordination and anticipation coupled with the horse's quality of submission, speed, attention, and finesse. The obstacles should be performed as quickly as possible without concern for style or movement. Any gait may be used.
- 2 A single judge is allowed, but a minimum of three judges is encouraged, with five preferred. Distribution around the arena shall be such that each judge has a clear view of all obstacles, with each judge having a different vantage point than the others.
- 3 The head judge will signal readiness to judge a test by using a bell or whistle. Upon the judge's signal, the entry shall have one minute to enter the arena and commence the test or be eliminated.
- 4 The course must be posted at least two hours before the scheduled start time of the phase.
- 5 All exhibitors entered in the phase will be allowed to inspect the course on foot with the judge and the course designer, if present, prior to the start of the phase. Exhibitors may be accompanied by their trainers during the walk through.
- 6 The Speed Trail phase obstacle course shall consist of the obstacles described in WE105.20 Ease of Handling phase. The available obstacles and number of obstacles shall be as described in WE105.4 except as modified below in sub item c. The Speed Trial course may contain different obstacles from the Ease of Handling phase course, or as an alternative, may utilize the same obstacles without moving obstacles. If the same obstacles are used, the line of course and order of execution must be changed to make the course differ from that used in the Ease of Handling phase.
  - a. Obstacle type 1 – Gate: A rope may be substituted in the Speed Trial phase in lieu of a constructed gate.
  - b. Obstacle types 13, 14, and 21 (corridors and side pass pole) may have balls between 6 and 7 cm in diameter placed in shallow dished supports which are attached to the supported poles, fences or walls defining the corridors. The shallow dished supports shall be designed such that a light impact with the supported pole will knock the ball off, which is evidence of the horse contacting the pole.
  - c. Obstacle types 8, 18, and 19 (picking up a pitcher of water, dismount, and unusual footing) shall not be included in a Speed Trial phase.
- 7 The Speed phase score is based on the time taken by the competitor to complete the course with the addition of time penalties for faults. The competitor with the lowest aggregate time (course time plus penalty time) shall be placed first, and successive places shall be awarded accordingly. Time penalties shall be assessed as follows:
  - a. Obstacle type 1 – Gate
    - (1) Dropping of the rope, when a rope is used in lieu of a constructed gate – 30 seconds (Rider may dismount to retrieve gate, remount, and finish obstacle).
    - (2) Failure to latch gate for the Intermediate level– 20 seconds
    - (3) Knocking over the gate uprights – 10 seconds
  - b. Obstacle type 2 and 5 – Retrieve a Lance and Replace a Lance - Knocking over a barrel – 5 seconds
    - (1) If rider drops the lance, or the lance does not stay in the barrel after placement, rider must dismount to retrieve lance and finish obstacle. Time shall continue through the dismount but there shall be no time penalties for dismount and retrieval.
  - c. Obstacle type 3 – Knock Down Balls and/or Catch a Ring at Various Heights and obstacle type 5 Hit a Shield.
    - (1) Knocking over any part of the obstacle – 10 seconds
    - (2) Failure to knock off ball or hit shield – 10 seconds
    - (3) Failure to skewer ring and place in barrel with lance – 10 seconds
  - d. Obstacle type 6 - Bridge - Knocking over any portion of the bridge – 5 seconds.

- e. Obstacle type 7 – Livestock Pen – Knocking over any part of the obstacle – 5 seconds.
  - f. Obstacle types 10 and 22 – Hay Jump and Hay Jump with Corridor
    - (1) Knocking top pole off – 5 seconds
    - (2) Dislodging hay bale(s) – 5 seconds.
    - (3) Failure to jump the obstacle – 15 seconds.
  - g. Obstacle types 11, 16, and 20 – Bending Poles, Bending Poles with Rein back, Parallel Bending Poles – Knocking over a pole – 3 seconds.
  - h. Obstacle types 12 and 15 - Figure 8 Between Barrels and Cloverleaf around Three Barrels - Knocking over a barrel: 5 seconds
  - i. Obstacle types 13, 14, and 21 – Ring a Bell at the End of a Corridor, “L” or “Z” Corridor, and Lateral Movement Over a Pole:
    - (1) If small balls are included in the obstacle, knocking a ball off the support – 3 seconds
    - (2) Failure to ring bell or move and place cup – 10 seconds.
  - j. Obstacle type 21 – Lateral Movement over a pole - Any leg stepping across the rail opposite of the indicated side – 5 seconds.
  - k. Obstacle type 26 – Pirouette in the Triangle – Not completing the full  $\frac{3}{4}$  pirouette – 5 seconds.
- 8 Elimination – Competitors shall be eliminated for the following errors:
- a. Uncorrected course fault.
  - b. Third refusal for any obstacle.
  - c. Failure to perform any obstacle.
  - d. Taking more than 20 seconds to begin execution of any obstacle.
  - e. Obstacle type 5: Failure of competitor to place lance into barrel. If lance is placed in the barrel but bounces out or falls out, competitor must dismount and retrieve lance, remount and place lance in barrel. Failure to do so shall result in elimination.
- 9 The event will be timed from the moment the horse’s nose first crosses the starting line to the time its nose first crosses the finish line. The starting and finish line may not necessarily be the same location.

## **WE 107 RESERVED**

### **WE 108 Requirements for Management**

- 1 Officials
  - a. The judges for the Working Equitation division must be chosen from judges knowledgeable in officiating Working Equitation.
    - (1) Three judges is a recommended minimum and five judges is preferred to officiate Working Equitation competitions.
    - (2) A single judge is allowed, but is recommended for smaller competitions only.
  - b. Stewards: A Show Steward is required.
    - (1) A Steward appointed by management should inspect horse and rider combinations before and after the phases and inform management and the judge of any irregularity regarding tack and attire or traces of blood. Responsibility for compliance, however, rests with the exhibitor.
- 2 Riding Arenas
  - a. The Dressage Phase is conducted within a standard 20x40 meter dressage arena. Although a complete arena with chain or block and rail construction is highly recommended, it is not required. When a complete arena is not used, the corners of the arena must still be delineated. Arenas shall have the letters appropriately marked.
  - b. The arena for the Ease of Handling and Speed phases is comprised of an area with minimum dimensions of 60x30 meters, with a minimum 70 meters on the long dimension preferred. It should be flat and be free of any stones or objects which could endanger competitors. It is recommended

that a sandy or a grassy surface without ruts be used. The surface of the arena may be compacted provided that it's not too hard or slippery.

- c. Each phase shall have a warm-up arena and a competition arena. Footing in the warm-up arena shall be similar to that of the competition arena. The warm-up arena shall be located near the competition arena.
- 3 Scribes: Each judge must be provided an individual to record scores. Scribes should have knowledge of the tests being ridden. Scribes should not be owners, coaches, trainers or family members of a competitor/horse in the class in which they are scribing. It is strongly recommended that scribes not compete before judges with whom they have worked as a scribe at the same competition.
- 4 Timed Phases: a timer is required. When a manual timer (person with stopwatch, as opposed to electronic timing) is used, the same timer must be used for all entries in a class. Electronic timing, where available, is highly recommended. Where electronic timers are used and the start/finish lines are different, 2 timer triggers are required. Competitions must provide a backup timer for these classes.
- 5 The head judge will be provided a bell or whistle by show management with which to signal riders to begin their trials. The bell or whistle is also used to signal an error to the rider or elimination per the rules of the applicable phase.

### **WE 109 General Scoring**

- 1 Competition Management may give awards in each phase as if each were an individual class. However, collectively, the multiple phases make up a Working Equitation section.
- 2 Overall competition points shall be awarded based upon the competitor's finishing rank within the phase. Each competitor finishing the phase shall be awarded one point for participation and one point for each participant ranked below the competitor by phase score. For example, if there are nine competitors, the points by place would be as follows:
 

1 <sup>st</sup> Place	9 points
2 <sup>nd</sup> Place	8 points
...	
8 <sup>th</sup> Place	2 points
9 <sup>th</sup> Place	1 point

- 3 After each phase, the judge will sign the scorecards and will then pass the judge's sheets to the scorers. Scores and comments must be written in ink. Any corrected score must be initialed by the judge making the correction. The marks are multiplied by the corresponding co-efficient where applicable and then totaled. Penalty points incurred for errors in the execution of the test are then deducted on each judge's sheet to obtain the total score for that phase.
- 4 The total overall Working Equitation Competition score is obtained by adding the total points for each phase. If there are two or more judges, the points awarded by each judge will be published separately in addition to the total score for the Dressage Phase and Ease of Handling Phase: Total final results must be published in marks as well as in percentages with numbers written to three decimal places. Scores should be publicly posted as soon as possible after each ride.
- 5 In the event of a tie for the overall competition, the overall impression scores for the Ease of Handling phase shall be used to break the tie, with the competitor with the higher score placing higher. In the event there is still a tie, the overall impression scores for the Dressage Phase shall be used to break the tie, again with the higher score placing higher. If a tie still exists, the competitor with the fastest aggregate time on the Speed phase shall place higher.
- 6 Team Classification. A Working Equitation team championship is determined by totaling up the scores of the riders in each team in each of the phases. The team with the highest number of points will be declared the winner.
- 7 If a competitor withdraws (scratches, etc.) prior to a class or is excused, eliminated or a "no show" prior to or during the performance of a phase, the words "scratched", "excused", "eliminated", or "no show" or abbreviations of such, must appear after the competitor's name on the results sheet.
- 8 Videotape may not be used to dispute a judge's decision.
- 9 Judges should not leave until all scores from the classes they officiated have been totaled and any ties resolved.
- 10 If a mathematical error on the score sheet is discovered, it must be brought to the attention of competition management within 1 hour of the official posting of the scores from the last class of that competition day. Competition Management must announce said posting, and must make the phase sheets available to competitors immediately upon resolving the error or by the beginning of the following competition day if exhibitors are no longer present at the time of the resolution.

### **WE 110 Elimination**

- 1 Horse/rider combinations shall be eliminated from the competition or from the current or next phase depending on which is closest to the time the incident occurred under the following circumstances:
  - a. Infraction of any state or federal law pertaining to the exhibition, care and custody of horses within the state or country where a Working Equitation class is being held.
  - b. Abuse of an animal in the show arena and/or evidence that an act of abuse has occurred prior to or during the exhibition of a horse in competition;
  - c. Illegal tack;
  - d. Use of whips in the competition arena.
  - e. Entering the arena before the judge has signaled readiness for the competitor to enter.
  - f. Entering the arena out of order from the posted entry order, unless directed by the judge/steward.
  - g. Taking more than one minute to begin the trial after the bell has been rung.
  - h. Fall of horse and/or rider.
  - i. Use of free hand to guide or signal the mount at the Intermediate level when the competitor has elected to ride with one hand.
  - j. At the Intermediate level when the competitor has elected to ride with two hands, release of the reins with one hand except when the instructions for completing the obstacle require the use of one hand free of the reins.

- k. Use of the rider's free hand to brush or stroke the horse's neck in front of his/her rein or providing any form of assistance to guide or cue the mount.
- l. Refusing to advance for a period of more than 20 seconds, except where and as outlined in the rules for elimination in the Ease of Handling phase.
- m. Failing to complete the pattern/course as given and/or posted.
- n. Leaving the arena during the trial prior to completing the pattern and/or being excused by the judge.
- o. Disrespect or misconduct by the exhibitor.
- p. The judge may excuse a horse at any time while in the arena for unsafe conditions, unruly behavior, or improper exhibition pertaining to the horse and/or rider. This may include the exhibition of an animal not in a fit or sound condition.
- q. The use of abusive equipment, and/or the use of abusive showing techniques by the rider;
- r. The exhibition of a horse with clear evidence of fresh blood in the mouth, nose, chin, shoulder, barrel, flank or hip area (those areas reasonable to believe the injury may have been caused by the rider or equipment).
- s. It should be noted that in every case the exhibitor should be given the benefit of doubt, should any doubt exist.
- t. Three errors in the Dressage phase.
- u. Overstepping the rectangular course delimitation in the Dressage phase.
- v. Failure to correct a course fault in the Ease of Handling phase.

### ***WE III Courses Score Sheets***

- 1 The first diagram is the Ease of Handling phase Score Sheet. This is available in .xlsx format for entering competition information.
- 2 The second diagram is a sample Speed phase Score Sheet. This is available in .xlsx format for entering competition information and sorting the order of obstacles to be performed.
- 3 Dressage phase score sheets/patterns, by level, are appended to this document. Descriptions of the required movements are outlined on each score sheet. Instructions relating to bits, whips, and spurs on those score sheets do not apply. The score sheets/patterns are used with the permission of Working Equitation USA.

<b>Ease of Handling Score Sheet</b>				<b>JUDGE (enter name)</b>		<b>(enter date of competition)</b>	
<b>BACK NO.</b> _____				<b>Horse</b> _____		<b>Year born</b> _____	
						<b>Class #</b> _____	
				<b>Rider</b> _____			
<b>N°</b>	<b>Name of Exercise</b>			<b>Score</b>	<b>Notes</b>		
1							
2							
3							
4							
5							
6							
7							
8							
9							
10							
11							
12							
13							
14							
15							
<b>NOTES FOR THE COURSE</b>							
<b>N°</b>	<b>Directive</b>			<b>Score</b>	<b>Notes</b>		
A	Canter and Walk						
	Transition canter/walk						
<b>OVERALL IMPRESSION</b>							
<b>N°</b>	<b>Directive</b>			<b>Score</b>	<b>Notes</b>		
B	Gaits				Freedom and regularity		
C	Impulsion Submission				Attention to obedience. Desire to move forward, elasticity of the steps. Engagement of the hindquarters		
D	Rider				Position and seat of the rider, correct use of aids, and effectiveness of aids.		
				<b>PENALTIES - (      )</b>			
<b>Judge's Signature:</b> _____					<b>TOTAL</b> _____ % _____		

<b>Speed Trial Score Sheet</b>										
Date: (enter date)		Judge: (enter name)			Signature _____					
Competitor # _____		Rider Name _____			Horse Name _____					
Obstacle Order	Obstacle Type	Obstacle Name	Faults						Total Penalty	Time
			Fault Type 1	<b>X</b>	Fault Type 2	<b>X</b>	Fault Type 3	<b>X</b>		
	1	Gate	Dropping the Rope - 30s		Failure to Latch Gate - 20s		Knocking over Gate Uprights- 10s			
	2	Retrieve a Lance from a Barrel	Knocking Over the Barrel- 5s							
	3	Knock Down Balls and/or Catch a Ring	Knocking Over any part of the Obstacle-10s		Failure to Knock Off Ball- 10s		Failure to Skewer Ring and Place in Barrel w/ Lance-10s			
	4	Hit a Shield	Knocking Over any part of the Obstacle-10s		Failure to Hit Shield-10s					
	5	Deposit a Lance in a Barrel	Knocking Over the Barrel- 5s		Failure to Place Lance in Barrel- Elimination					
	6	Bridge	Knocking Over Any Part of the Bridge-5s							
	7	Livestock Pen	Knocking Over any part of the Obstacle-5s							
	8	Pick up a Pitcher of Water								
	9	Move a Sack								
	10	Hay Bale Jump	Knocking Top Pole Off-5s		Dislodging Hay Bale(s) or lower pole-5s		Failure to Jump Obstacle-15s			
	11	Pole Bending	Knocking Over a Pole-3s							

	12	Figure 8 Around Two Barrels	Knocking Over a Barrel-5s					
	13	Ring a Bell at the End of a Corridor	Knocking Over a Ball on Obstacle-3s	Failure to Ring Bell or move cup-10s				
	14	L or Z Corridor	Knocking Over a Ball on Obstacle-3s	Failure to Ring Bell or move cup-10s				
	15	Cloverleaf Around Three Barrels	Knocking Over a Barrel-5s					
	16	Parallel Pole Bending		Knocking Over a Pole-3s				
	17	Move a Ball in a Corridor						
	18	Dismount, Walk Around Horse, and Remount						
	19	Unusual Footing						
	20	Pole Bending with Reinback	Knocking Over a Ball on Obstacle-3s	Knocking Over a Pole-3s	Failure to Ring Bell- Elimination			
	21	Sidepass Pole	Knocking Over a Ball on Obstacle-3s	Any leg stepping across the rail - 5s				
	22	Hay Bale Jump with a Corridor	Knocking Top Pole Off-5s	Dislodging Hay Bale(s)-5s	Failure to Jump Obstacle- Elimination			
	23	Cross a Ditch Containing Water						
	24	Embankment						
	25	Herding Cattle from Gate to Gate						
	26	Pirouette in the Triangle	Not performing the full 3/4 pirouette - 5s					
					TOTAL PENALTY TIME			
					TOTAL COURSE TIME			
					TOTAL TRIAL TIME			
OTHER ELIMINATION FAULTS								



# WORKING EQUITATION DRESSAGE TEST

## BASIC

**PURPOSE:** To test the correct progression of the horse's training at the Basic level. To introduce the beginnings of lateral work. To be ridden in a snaffle. Rider may carry a whip. Spurs allowed. The horse should now be reliably in acceptance of the aids, with more impulsion and with a rounded and more uphill balance in the working gaits then at Novice Level.

Rider No. \_\_\_\_\_

Rider Name \_\_\_\_\_

Judge \_\_\_\_\_

Name of Horse \_\_\_\_\_

Date \_\_\_\_\_

Name of Competition \_\_\_\_\_

	TEST	JUDGING		POINTS	REMARKS
1.	<b>A</b> Enter Working Trot	Straightness, Relaxation, Impulsion			
<b>X</b>	Halt from Trot. Salute	Straightness, Obedience, Suppleness, Relaxation, Balance			
	Proceed Working Trot	Impulsion, Straightness, Balance, Suppleness			
2.	<b>C</b> Track Right	Bend, Balance and Impulsion Impulsion, Balance, Length of Strides, Regularity of Tempo			
<b>MXK</b>	Lengthen Strides	Suppleness, Balance, Regularity of Tempo.			
<b>K</b>	Working Trot				
3.	<b>A</b> Working Canter Left Lead	Suppleness, Balance, Straightness, Relaxation			
4.	<b>M</b> Turn Left	Balance, Bend, Impulsion			
<b>G</b>	Circle Left 14m 1 and ½ times	Relaxation, Bend, Balance, Impulsion			

5. <b>X</b>	Trot and Circle Right 10m	Suppleness, Bend, Impulsion			
<b>X</b>	Straight ahead	Straightness, Balance			
<b>B</b>	Turn Right	Bend, Balance, Impulsion			
6. <b>A</b>	Turn Down Centerline	Bend and Balance in Turn. Straightness, Relaxation, Impulsion			
<b>D - M</b>	Leg Yield Right	Relaxation, Straightness and Crossing			
7. <b>C</b>	Medium Walk	Relaxation, Length of Strides, Connection			
8. <b>H</b>	Turn Left	Relaxation and Bend			
<b>G</b>	Half Turn on the Forehand away from Left Leg.	Relaxation, Suppleness, Obedience to Aids, Connection			
9. <b>H</b>	Turn Left	Bend and Relaxation			
<b>E-F-A</b>	Free Walk on Long Rein	Relaxation, Length of Strides, Energy, Connection			
<b>A</b>	Medium Walk	Suppleness, Length of Strides, Connection			
10. <b>K</b>	Turn Right	Relaxation and Bend			
<b>D</b>	Half Turn on the Forehand away from the Right Leg	Relaxation, Suppleness, Obedience to Aids, Connection			
11. <b>K</b>	Turn Left	Bend, Balance, Length of Stride, Relaxation			
<b>A</b>	Working Trot	Balance, Straightness, Impulsion			

12. <b>FXH</b>	Lengthen Strides	Suppleness, Impulsion, Balance, Length of Strides, Regularity of Tempo			
<b>H</b>	Working Trot	Suppleness, Balance, Regularity of Tempo.			
13. <b>C</b>	Working Canter Right Lead	Suppleness, Balance, Straightness, Relaxation			
14. <b>C</b>	3 loop Serpentine with Changes of lead through the trot upon crossing the center line	Obedience, Relaxation, Straightness, Balance			
15. <b>K-H</b>	Lengthen the Canter	Impulsion, Straightness, Relaxation, Regularity, Length of Frame and Strides			
16. <b>H-C</b>	Working Canter	Obedience, Suppleness, Straightness, Regularity			
17. <b>F</b>	Turn Right	Balance, Bend, Impulsion			
<b>D</b>	Circle Right 14m 1 and ½ times	Relaxation, Bend, Balance, Impulsion			
18. <b>X</b>	Trot and Circle Left 10m	Suppleness, Bend, Impulsion			
<b>X</b>	Straight Ahead	Straightness, Balance			
<b>B</b>	Turn Right	Bend, Balance, Impulsion			
19. <b>A</b>	Down Center Line	Bend and Balance in Turn. Straightness, Relaxation, Impulsion			
<b>D - H</b>	Leg Yield Left	Relaxation, Straightness and Crossing			

20. <b>Between M and B</b>	Halt. Rein Back 3 to 4 Strides. Proceed Working Trot.	Straightness, Obedience, Suppleness, Relaxation, Balance			
21. <b>A</b>	Turn down Centerline	Straightness, Relaxation, Impulsion			
<b>G</b>	Halt from the Trot. Salute	Straightness, Obedience, Suppleness, Relaxation, Balance			

**COLLECTIVE MARKS**

<b>Gaits</b>	Purity and Regularity	1		
<b>Impulsion</b>	Desire to move Forward, Suppleness of the back, Engagement of the Hindquarters	2		
<b>Submission</b>	Obedience, Confidence, Harmony with Rider, Acceptance of the bridle, Ease of Movements	2		
<b>Rider Position</b>	Correct use and effect of the Aids, Rider's position.	2		
<b>Presentation and Turnout</b>	Correctness of Tack and Attire. Neatness and Polish	1		

Maximum points                    290

Points Earned                    (         )

Errors                                (-         )

Total Points                      (         )

Percentage

Judge \_\_\_\_\_



# WORKING EQUITATION DRESSAGE TEST

## INTERMEDIATE

**PURPOSE:** To test the correct progression of the training at the Intermediate level and to introduce the half pass and flying changes. To be ridden in a snaffle, Pelham, curb, or double bridle. Rider may NOT carry a whip. Spurs allowed. The horse now accepts and responds readily to the aids of the rider. This level has greater levels of Impulsion and collection than at the Preliminary level. Reins will be held in one hand for the walk and the trot. All collected trot is done sitting.

Rider No. \_\_\_\_\_

Rider Name \_\_\_\_\_

Judge \_\_\_\_\_

Name of Horse \_\_\_\_\_

Date \_\_\_\_\_

Name of Competition \_\_\_\_\_

NO	TEST	JUDGING	POINTS	REMARKS
1	Enter at the collected Canter on the center line. Halt and salute facing the judge.	Uphill balance and straightness, immobility in halt.		
<b>MOVEMENTS AT THE WALK</b>				
2	From the halt, continue in Medium Walk a minimum of 12m. with the reins in one hand.	Relaxation, swing, purity, regularity, activity, and ground cover.		
3	Collect the walk and describe a figure of 8 with each half describing a 10m circle.	Bend, balance, collection, regularity, purity, and activity		
4	Half Pirouette Right	Rhythm, bend, suppleness, roundness, collection, size of turn.		

5	Extended walk a minimum of 20 meters  Collect the Walk	Lengthening of Frame And stride, relaxation Suppleness in transitions without loss of activity in the collected walk		
6	Half Pirouette Left  Continue Straight Ahead	Rhythm, bend, suppleness, roundness, collection, size of turn.		
7	Halt and Reinback 4 to 8 steps	Obedience, straightness, lowering of haunches, roundness, relaxation		
<b>MOVEMENTS AT THE TROT</b>				
8	Depart Reinback in Collected Trot.	Prompt move off, suppleness, roundness, collection		
9	Describe 3 circles to the right: the first circle (20m) must be performed at extended trot; second (15m) working trot; third (10m) collected trot. All the circles must begin and finish at the same point.	Regularity, Balance, Collection. Transitions to be prompt, fluid and should be performed all at same point.		
10	Half Pass right from the long side to the center line using the length of the arena.	Relaxation, bend, impulsion, collection		
11	Describe 3 circles to the left: the first circle (20m) must be performed at extended trot; second (15m) working trot; third (10m) collected trot. All the circles must begin and finish at the same point.	Regularity, Balance, Collection. Transitions to be prompt, fluid and should be performed all at same point.		

12	Half Pass left from the long side to the center line using the length of the arena.	Relaxation, bend, impulsion, collection		
<b>MOVEMENTS AT THE CANTER</b>				
13	Reins in two hands and collected canter left lead.	Promptness of depart, relaxation, suppleness, collection.		
14	Change rein across the diagonal in collected canter with a flying change after X.	Length of stride and frame, uphill balance in Medium. Clear, clean, straight, and uphill balanced change.		
15	Extended Canter across the diagonal	Length of stride and frame, uphill balance.		
16	Collected canter and flying change before the corner.	Clear transition with no resistance, clear, clean, straight and uphill balanced change of lead.		
17	Turn down the centerline and Half Pass left to the long side. Use the length of the arena.	Relaxation, bend, impulsion, and collection.		
18	Flying Change	Relaxation, clear and clean change, straightness, and uphill balance.		
19	Turning down the centerline and Half Pass right to the long side. Use the length of the arena	Relaxation, bend, impulsion, and collection.		
20	Flying Change			
22	Three loop serpentine with flying changes on crossing the center line	Accuracy, relaxation, straightness, clear and clean change, uphill balance.		
23	Turn down the Center line. Halt and salute facing the judge.	Uphill balance and straightness, immobility in halt.		

**COLLECTIVE MARKS**

<b>Gaits</b>	Purity and Regularity	1		
<b>Impulsion</b>	Desire to carry the rider energetically uphill with relaxation.	2		
<b>Submission</b>	Obedience, confidence, harmony with rider, acceptance of the aids, and the ease of the movements.	2		
<b>Rider Position</b>	Correct use and effect of the aids. Correct rider position.	2		
<b>Presentation and Turnout</b>	Correctness of Tack and Attire. Neatness and polish.	1		

Maximum points:            310

Points Earned:            (        )

Judge \_\_\_\_\_

Errors:                      (-        )

Total Points:            (        )

Percentage: